

M-126 Linear Slide

Linear Stage with Crossed Roller Bearings



M-126.CG1 translation stage with compact DC motor/gearhead

- To 25 mm Travel Range
- Manual, DC-Servo and Stepper-Motor Drives
- ActiveDrive™ Option
- Compatible with Leading Industrial Motion Controllers
- Crossed Roller Bearings
- <0.1 μm Resolution
- XY and XYZ Combinations
- Direction-Sensing Origin Switch
- Non-Contact Limit Switches

M-126 systems are high-resolution translation stages with leadscrew and ballscrew drives. Precision crossed roller bearings guarantee straightness of travel of better than 2 μm.

All models are equipped with low-friction leadscrews for excellent resolution and repeatability. Three motorized versions are available: M-126.CG1 utilizes a compact closed-loop DC motor with shaft-mounted high-resolution position encoder and a precision gearhead providing 0.1 μm minimum incremental motion, M-126.DG1 is equipped with a larger motor than M-126.CG1 and provides higher velocity.

ActiveDrive™

M-126.PD1 and .PD2 are equipped with the high-performance ActiveDrive™. This

novel design features a high-efficiency PWM servo-amplifier mounted side-by-side with the DC motor.

The ActiveDrive™ provides several decisive advantages:

- Increased efficiency by eliminating power losses between the amplifier and motor
- Reduced cost of ownership and improved reliability because no external driver is required
- Elimination of PWM amplifier noise radiation by mounting the amplifier and motor together in a single electrically shielded case

Model M-126.2S1 is equipped with a micro-stepped 2-phase stepper motor.

Non-Contact Limit and Origin Switches

Non-contacting, Hall-effect limit and direction sensing origin switches are integrated into the motorized versions to protect your equipment.

All stages can be cross-stacked and combined with the M-125.90 Z-axis mounting bracket to provide multi-axis motion.

Notes

See "Accessories", page 7-92 ff. for adapters, brackets, etc.

Ordering Information

M-126.CG1
Translation Stage, 25 mm, Compact DC Motor / Gearhead

M-126.DG1
Translation Stage, 25 mm, DC Motor / Gearhead

M-126.PD1
Translation Stage, 25 mm, ActiveDrive™ DC Motor (power supply included)

M-126.PD2
Translation Stage, 20 mm ActiveDrive™ DC-Motor Ball Screw (power supply included)

M-126.2S1
Translation Stage, 25 mm, 2-Phase Stepper Motor

M-126.M0
Translation Stage, 25 mm, Manual Drive, Leadscrew

M-125.90
Z-axis Mounting Bracket for Vertical Mount of M-126 Stages

Ask about custom designs!

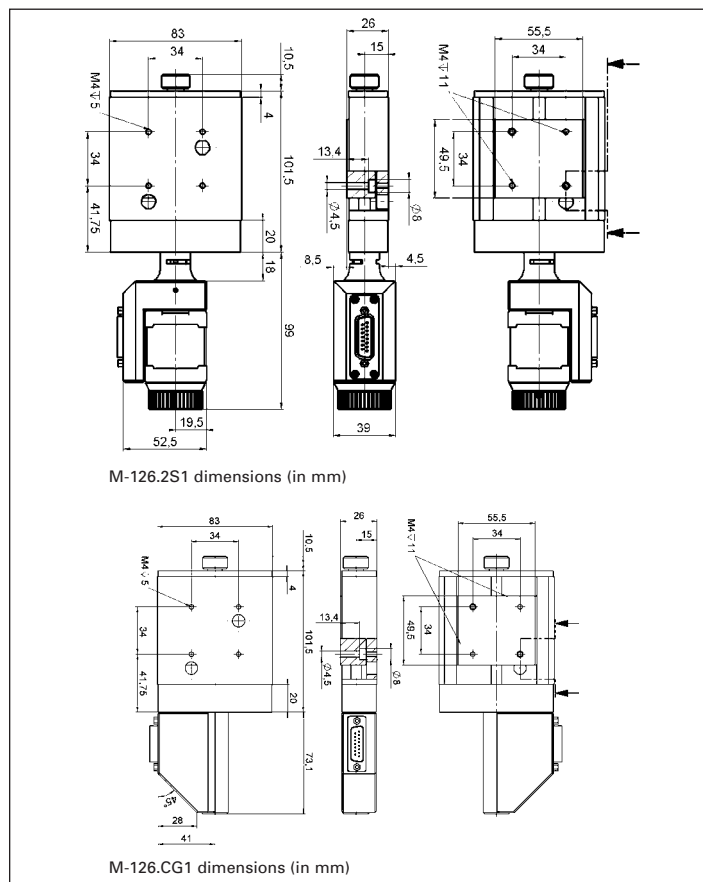

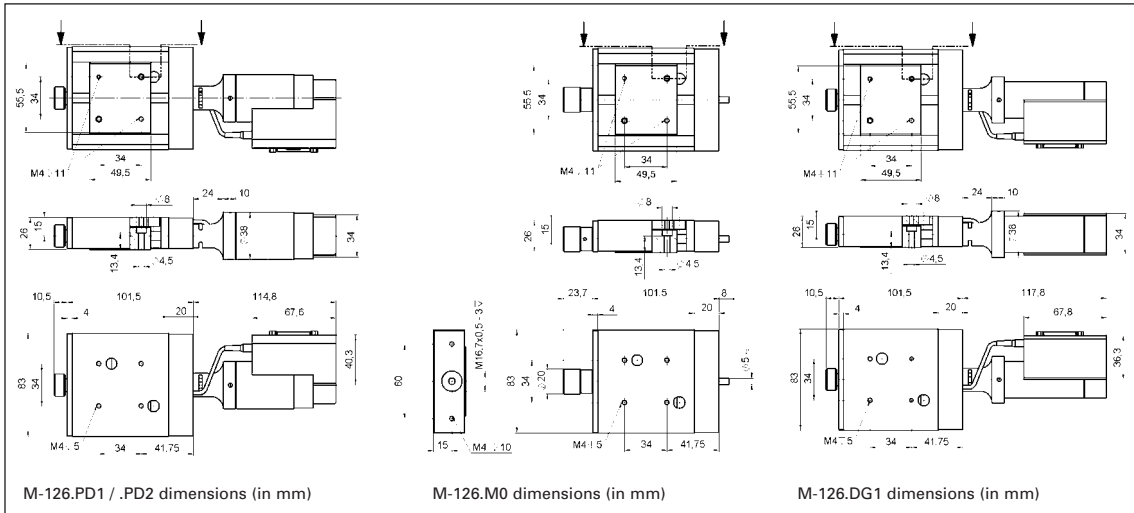

Technical Data

Models	M-126.M0	M-126.CG1	M-126.DG1	M-126.PD1	M-126.PD2	M-126.2S1	Units	Notes see page 7-106
Travel range	25	25	25	25	20	25	mm	
Design resolution	-	0.0035	0.0085	0.125	0.25	0.05	µm	A3
Min. incremental motion	1	0.1	0.1	0.25	0.25	0.1	µm	A4
Unidirectional repeatability	-	0.2	0.1	0.1	0.25	0.1	µm	
Bidirectional repeatability	-	2	1	1	1	1	µm	
Straightness	2	2	2	2	2	2	µm	
Flatness	2	2	2	2	2	2	µm	
Pitch (θ_y)	50	50	50	50	50	50	µrad	
Yaw (θ_z)	50	50	50	50	50	50	µrad	
Max. velocity	-	1	1.5	*15	50	6	mm/sec	
Max. normal load capacity	20	20	20	20	20	20	kg	B1
Max. push/pull force	50 / 50	40 / 40	50 / 50	50 / 50	50 / 50	50 / 50	N	B2
Max. lateral force	100	100	100	100	100	100	N	
Encoder resolution	-	2048	2000	4000	4000	-	counts/rev.	
Motor resolution	-	-	-	-	-	20,000**	steps/rev.	
Leadscrew pitch	0.5	0.5	0.5	0.5	1	0.5	mm/rev.	
Gear ratio	-	69.12:1	(28/12) ¹ :1 ≈ 29.6:1	-	-	-		
Nominal motor power	-	2	3	30	30	- **	W	
Motor voltage	-	12	12	24	24	24 **	V	
Weight	0.6	0.8	0.9	0.9	0.9	1.0	kg	
Body material	Al, St	Al, St	Al, St	Al, St	Al, St	Al, St		L
Recommended motor controller	-	C-843, C-848	C-843, C-848, C-843, C-848	C-843, C-848	C-843, C-848	C-600, C-630		D2

C-815.38 motor cable included: 3 m, sub-D, 15/15 pin (m/f).

* max. recommended velocity. ** 2-phase stepper, 24 V chopper voltage, max. 0.8 A / phase, 20,000 microsteps with C-600, C-630 controllers.

Piezo Actuators

Nanopositioning & Scanning Systems

Active Optics / Steering Mirrors

Tutorial: Piezo-electrics in Positioning

Capacitive Position Sensors

Piezo Drivers & Nanopositioning Controllers

Hexapods / Micropositioning

Photonics Alignment Solutions

Motion Controllers

Ceramic Linear Motors & Stages

Index