

M-663 Linear Slide

PILine® Linear Stage with Ultrasonic Piezomotor and Integrated Linear Encoder



PILine® M-663 micropositioning stages with integrated linear encoder and C-866 controller/driver in the background

- **Smallest Translation Stage with Closed-Loop Linear Motor and Encoder**
- **Travel Range 19 mm**
- **Max. Velocity 400 mm/s**
- **Accelerations up to 10 g**
- **Direct-Metrology Linear Encoder**
- **0.1 µm Resolution**
- **XY Combinations Possible**
- **Vacuum-Compatible Versions Available**

PILine® M-663 micropositioning systems offer high velocities of up to 400 mm/s and travel ranges of 19 mm in a compact package. The M-663 is the smallest closed-loop trans-

lation stage with piezomotor drives currently on the market. Its square footprint makes it suitable for use in compact XY configurations.

Working Principle

PILine® motors have a new, patented, ultrasonic drive developed by PI. The core piece of the system is a piezoceramic plate, which is excited to produce high-frequency eigenmode oscillations. A friction tip attached to the plate moves along an inclined linear path at the eigenmode frequency. Through its contact with the friction bar, the moving part of the mechanics drives forward or backwards. With each oscillatory cycle, the

mechanics execute a step of a few nanometers; the macroscopic result is smooth motion with a virtually unlimited travel range.

Advantages of PILine® Micropositioning Systems

The ultrasonic piezoceramic drives used in PILine® micropositioners have a number of advantages over classical drives:

- Higher Accelerations, up to 10 g
- Speeds up to 500 mm/s
- Small Form Factor
- Self-Locking When Powered Down
- No Shafts, Gears or Other Rotating Parts
- Non-Magnetic and Vacuum-Compatible Drive Principle

Optimized Controller and Drive Electronics

PILine® motors require a special drive electronics to generate the ultrasonic oscillations for piezoceramic element. For optimum performance the highly specialized C-866 motion controller is recommended. This sophisticated controller also integrates the drive electronics. Furthermore, the controller has a number of special features, including dynamic parameter switching for an optimized high-speed motion and settling behavior to take into account the motion characteristics typical of piezomotors. The broad-band encoder input (35 MHz) supports the outstanding high accelerations and velocities of PILine® drives at high resolutions.

Optionally, for use with third party servo controllers, the C-185 analog drive electronic (stand-alone unit) is available. It controls the motor speed by an analog ±10 V signal. For optimum performance the driver must be tuned together

Ordering Information

M-663.465
PILine® Translation Stage, 20 mm, Linear Encoder, 0.1 µm Resolution

M-663.Y65
PILine® Translation Stage, 20 mm, Linear Encoder, 0.1 µm Resolution, turned cable outlet, XY mountable

M-663.46V
PILine® Translation Stage, 20 mm, Linear Encoder, 0.1 µm Resolution, Vacuum Compatible to 10⁻⁶ hPa

Accessories:

C-866.161
Piezomotor Controller with Drive Electronics, 1 Channel, for PILine® Systems with P-661 Motors

Driver for use with separate controller:

C-185.161
Analog Stand-Alone Drive Electronics with Power Supply for PILine® P-661 Motors

with the stage and should be ordered at the same time as the motor/stage.

Note

The products described in this document are in part protected by the following patents:
US Pat. No. 6,765,335
German Patent No. 10154526

Application Examples

- Biotechnology
- Micromanipulation
- Microscopy
- Quality assurance testing
- Metrology
- Mass storage device testing
- R&D
- Photonics packaging

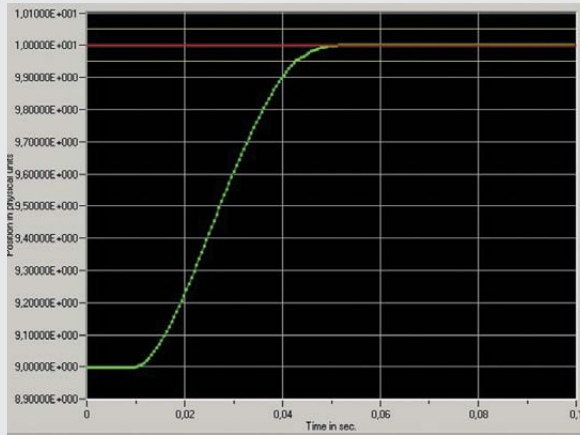

A 1 mm step performed by an M-663 stage with 300 g load controlled by a C-865 controller/driver reaches the end position in less than 40 ms

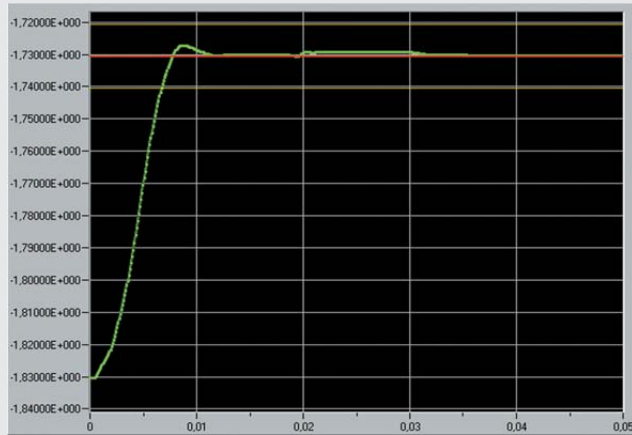

An M-663 with 100 g load settles to 0.1 μm accuracy in 10 ms after a 100 μm step, measured with C-865 Controller/Driver

Technical Data

Models	M-663.465	Units	Notes, see page 10-28
Active axes	X		
Motion and positioning			
Travel range	19	mm	
Integrated sensor	Linear encoder		
Sensor resolution	0.1	μm	
Min. incremental motion	0.1	μm	typ.
Backlash	± 0.3	μm	typ.
Unidirectional repeatability	0.2	μm	typ.
Pitch	300	μrad	typ.
Yaw	300	μrad	typ.
Max. velocity	400	mm/s	
Reference switch repeatability	1	μm	typ.
Mechanical properties			
Max. load	5	N	
Max. push/pull force	2	N	
Max. holding force	2	N	
Drive properties			
Motor type	P-661 PLine® ultrasonic piezomotor		
Operating voltage	120 (peak-peak)* 42 (RMS)*	V	
Electrical power	5**	W	nominal
Current	400**	mA	
Reference switch	Hall-effect		
Miscellaneous			
Operating temperature range	-20 to +50	$^{\circ}\text{C}$	
Material	Al (black anodized)		
Dimensions	35 x 35 x 15	mm	
Mass	40	g	$\pm 5\%$
Cable length	1.5	m	$\pm 10\text{ mm}$
Connector	MDR, 14-pin		
Recommended controller/driver	C-866.161 Single-axis controller/driver C-185.161 Drive electronics		

* Power is supplied by the drive electronics

** For drive electronics

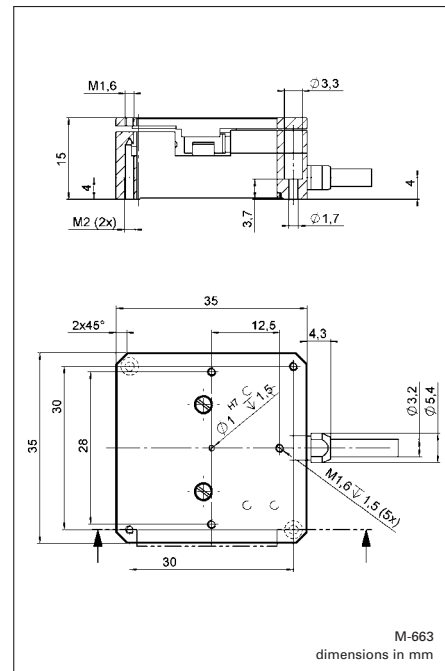

M-663
dimensions in mm



XY combination of two M-663s; CD for size comparison